

Distributed Source Coding for Image and Video Applications

Ngai-Man (Man) CHEUNG

Signal and Image Processing Institute
University of Southern California

<http://biron.usc.edu/~ncheung/>

Acknowledgements

- Collaborators at USC:
 - Antonio Ortega
 - Huisheng Wang
 - Caimu Tang
 - Ivy Tseng
- Some materials taken from literatures:
 - Xiong et al (Texas A&M)
 - Girod et al (Stanford)
 - Ramchandran et al (UC Berkeley)
 - Others

- Introduction
 - Motivation
 - Source coding with decoder side-information only
 - Simple example to illustrate DSC idea
 - Application scenarios
- Basic information-theoretic results
 - Slepian-Wolf
 - Wyner-Ziv
- Practical encoding/decoding algorithm
 - Role
 - LDPC based
- Applications
 - Low-complexity video encoding
 - Scalable video coding
 - Flexible decoding, e.g., multiview video

Motivation

Compression with Closed-loop Prediction (CLP): E.g., MPEG, H.26X

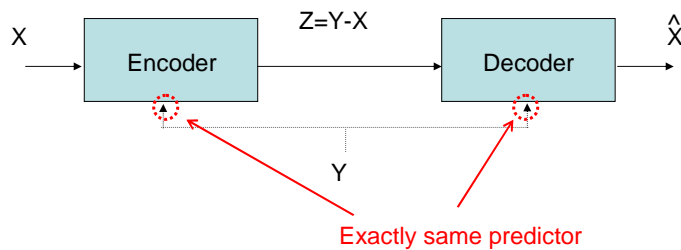

- Compute and send the difference/prediction residue ($Z=Y-X$) to decoder
- Predictor Y :
 - Motion-compensated predictor in neighboring frames
 - Co-located pixels in neighboring slices in volumetric image

Issues in Closed-loop Prediction: High Complexity Encoding

- High complexity encoding
 - Motion estimation

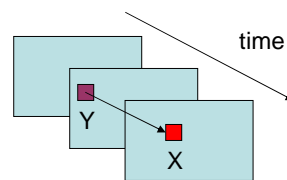

- Some emerging applications require low complexity encoding, e.g., mobile video, video sensors

Distributed source coding allows flexible distribution of complexity between encoder and decoder

Issues in Closed-loop Prediction: Vulnerable to Transmission Error

- Error in predictor propagates to subsequent frames: drifting

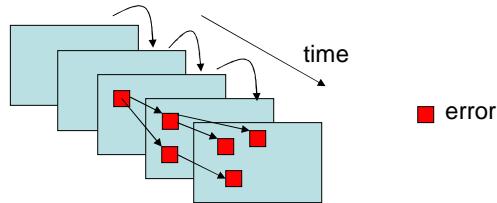

Distributed source coding allows exact reconstruction with transmission error

Issues in Closed-loop Prediction: Lack of Decoding Flexibility

- Some emerging applications need to support multiple decoding paths, e.g., multiview video

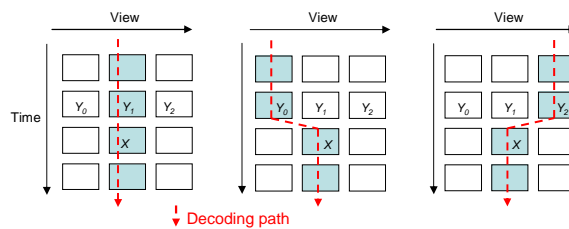

- When users can choose among different decoding paths, it is not clear which previous reconstructed frame will be available to use in the decoding

DSC can support multiple decoding paths and address predictor uncertainty efficiently

Distributed Source Coding

Distributed Source Coding

Lossless compression of random variable X
- Intra coding: $R \geq H(X)$

(i) CLP (e.g. DPCM):

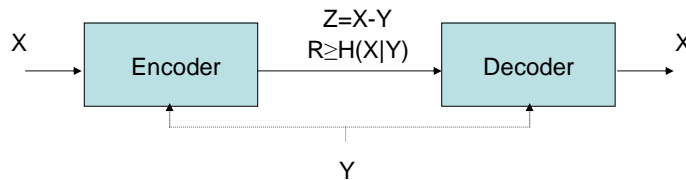

(ii) DSC:

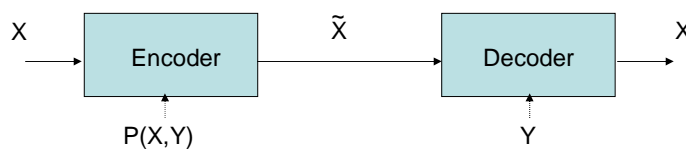

- **Encoding does not require Y**
 - Y de-coupled from the encoded data \tilde{X}

Distributed Source Coding

Lossless compression of random variable X
- Intra coding: $R \geq H(X)$

(i) CLP (e.g. DPCM):

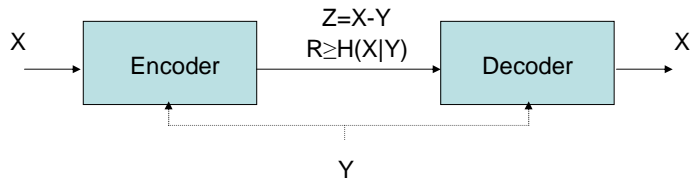

(ii) DSC:

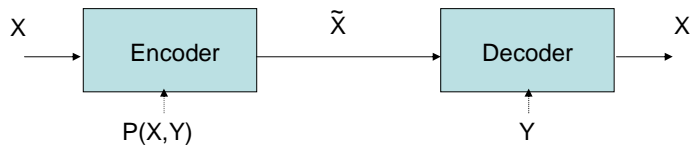

- **Encoding does not require Y**
 - Y de-coupled from the encoded data \tilde{X}

Distributed Source Coding

Lossless compression of random variable X
- Intra coding: $R \geq H(X)$

(i) CLP (e.g. DPCM):

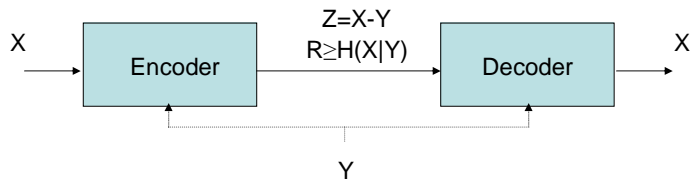

(ii) DSC:

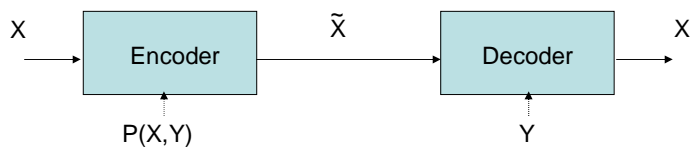

- **Encoding does not require Y**
 - Y de-coupled from the encoded data \tilde{X}

Distributed Source Coding

Lossless compression of random variable X
- Intra coding: $R \geq H(X)$

(i) CLP (e.g. DPCM):

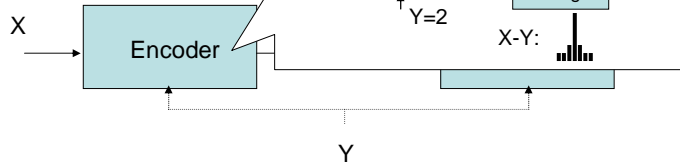

- Access to exact value of Y
- Compute the residue
- Use entropy coding to achieve compression

(ii) DSC:

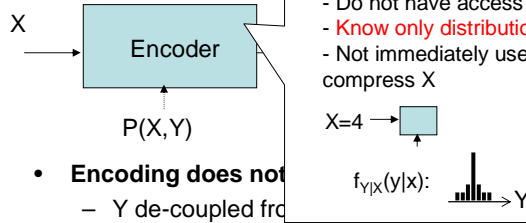

- Do not have access to exact value of Y
- Know only distribution of Y given X
- Not immediately useful since we want to compress X

- Encoding does not require Y
- Y de-coupled from the encoded data \tilde{X}

Distributed Source Coding

Lossless compression of random variable X
- Intra coding: $R \geq H(X)$

(i) CLP (e.g. DPCM):

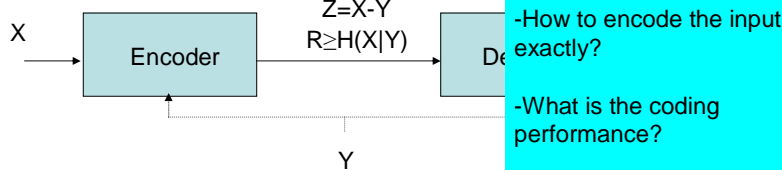

(ii) DSC:

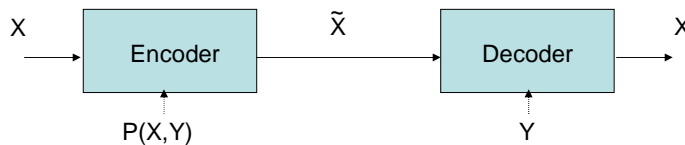

- Encoding does not require Y
- Y de-coupled from the encoded data \tilde{X}

Why DSC? When predictor is not available during encoding

- Correlated sources are not co-located
 - Sensors network, wireless camera
- Low complexity video encoding
 - Due to complexity constraint at the encoder

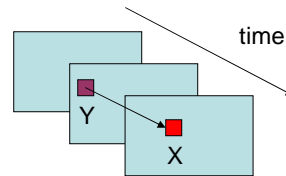

DSC:

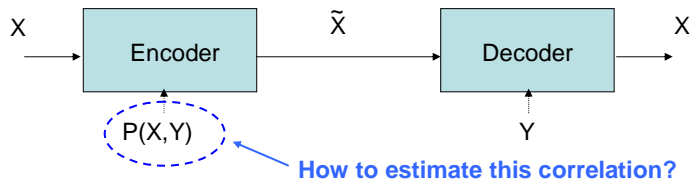

Why DSC? To "decouple" compressed data from predictor

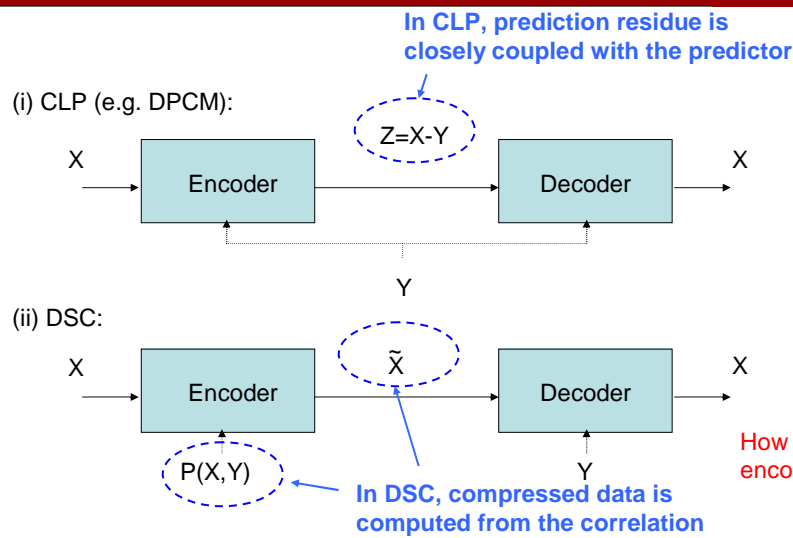

DSC – Example Using Coset

- X takes value [0, 255] (uniformly)
 - Intra coding requires 8 bits for lossless
- Correlation $P(X,Y): 4 > Y-X \geq -4$ (i.e., $Y-X$ takes value in $[-4,4)$)
 - Can explore this correlation
- If Y is available at both the encoder and decoder
 - CLP: communicate the residue

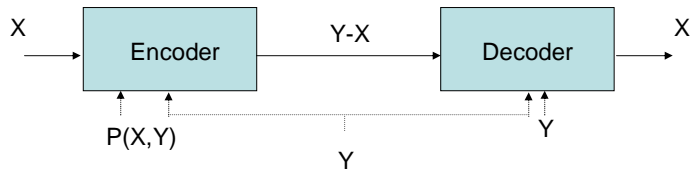
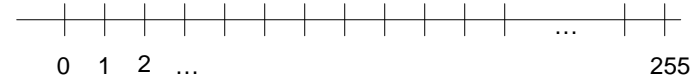

Requires 3 bits to convey X

If Y is not available at the encoder, how can we communicate X?

DSC – Example Using Coset (Cont'd)

- How to communicate X if Y is not available at the encoder?

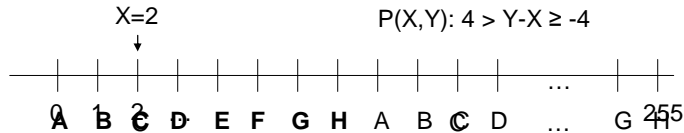

- **Partition** reconstruction levels into different cosets
 - Each coset includes several reconstruction levels
- Encoder: **transmit coset label** (syndrome), need 3 bits
- Decoder: **disambiguate** label (closest to Y)

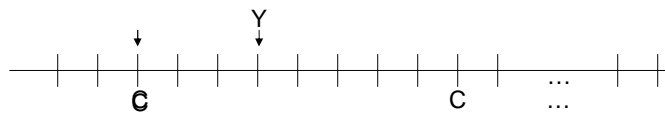

Requires 3 bits to convey X

DSC – Example Using Coset (Cont'd)

- Can we use less than 3 bits?
- Try 2 bits

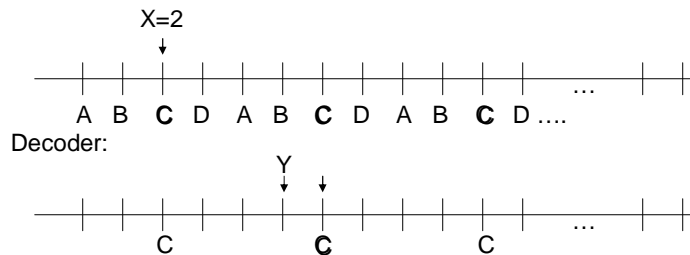

Decoding error if we use less bits than required

- Correlation information determines the number of coset for error-free reconstruction
- If correlation were $2 > Y - X \geq -2$ (i.e., X, Y are more correlated), 2 bits would work

DSC - Main Ideas

- Encoding: Send **ambiguous** information to achieve compression
 - E.g., one label represents group of reconstruction levels
- Decoding: information is **disambiguated** at the decoder using side information Y
 - Pick the coset member closest to Y
- “Level of ambiguity” (hence the encoding rate) is determined by correlation between X and Y
 - More correlated, more ambiguous representation using less bits

DSC - Main Steps

- Partition input into cosets
- Members in the coset are separated by minimum distance
- Send coset index
- At decoder, pick the member closest to side information in the coset
- **Similar steps for advanced algorithm based on error correction code (E.g., LDPC)**

How about the coding efficiency?

DSC – Theoretical Performance

Lossless compression of random variable X

- CLP

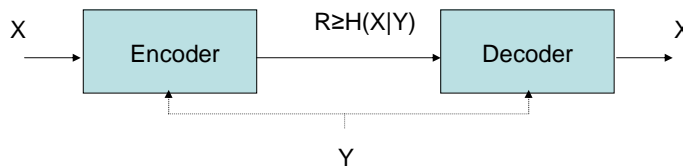

- DSC

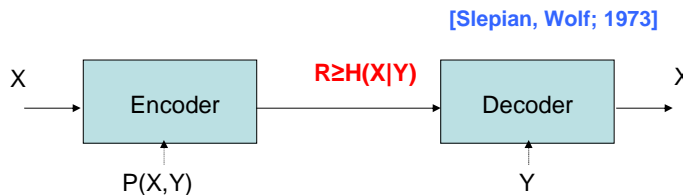

[Slepian, Wolf; 1973]

Efficient encoding possible even when encoder does not have precise knowledge of Y

DSC Properties - Inherent Error Resilience

- Even Y is corrupted by noise, it is still possible to reconstruct X exactly
 - Prevent error propagation

Encoder:



Decoder:

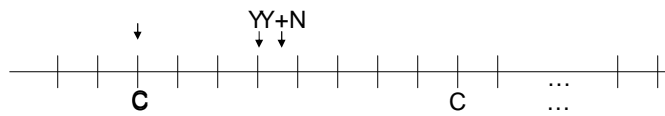

Compressed data (i.e., coset label) is decoupled from Y

DSC Properties – Robust to Predictor Uncertainty

- Multiple predictor candidates at the decoder (e.g., multiview video)
 - Encoder does not know exactly which predictor is available at decoder

Encoder:



Decoder:

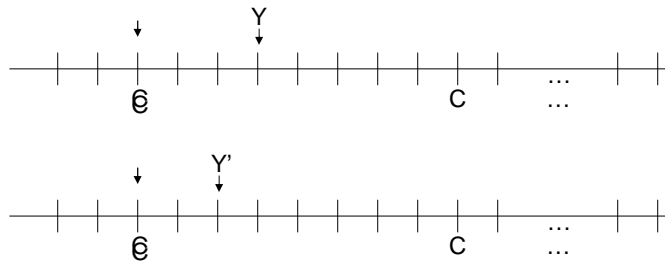

Application Scenario

Application Scenario – Video Transmission

- Resilience to transmission error
- In practical applications, we have to estimate the noise power at the encoder

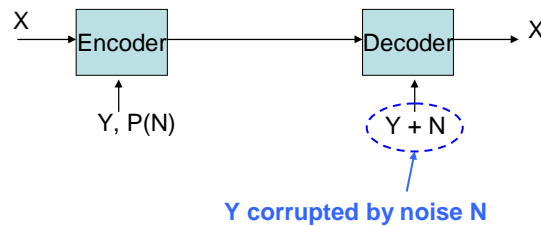

[Sehgal, Jagmohan, Ahuja; IEEE Trans. Multimedia 04],
[Majumdar, Wang, Ramchandran, Garudadri; PCS 04],
[Rane, Girod; VCIP 06], ...

Application Scenario – Flexible Decoding

Flexible decoding, e.g., multiview video

- DSC is robust to predictor uncertainty
- Encoder estimates correlation between X and Y_k
- Recover X exactly no matter which Y_k is at decoder

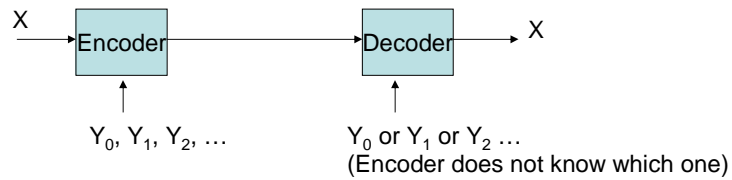

[Cheung, Ortega; MMSP 07]

Application Scenario – Low Complexity Video Encoding

Low complexity video encoding

- Finding Y to predict X is complex
- $P(X, Y)$ can be estimated in low complexity, hopefully...



[Puri, Ramchandran, Allerton 02]
[Aaron, Zhang, Girod, Asilomar 02], ...

Outline

- Introduction
 - Motivation
 - Source coding with decoder side-information only
 - Simple example to illustrate DSC idea
 - Application scenarios
- Basic information-theoretic results
 - Slepian-Wolf
 - Wyner-Ziv
- Practical encoding/decoding algorithm
 - Role
 - LDPC based
- Applications
 - Low-complexity video encoding
 - Scalable video coding
 - Flexible decoding, e.g., multiview video

Slepian-Wolf Theorem

- Lossless compression of correlated sources: $\mathbf{X}=\{X\}$, $\mathbf{Y}=\{Y\}$
- Random variables X , Y jointly distributed $P(X,Y)$
- **Possible to achieve total rate as low as $H(X,Y)$ - theoretical limit when the encoders can cooperate**
- Decoder side-information is a special case

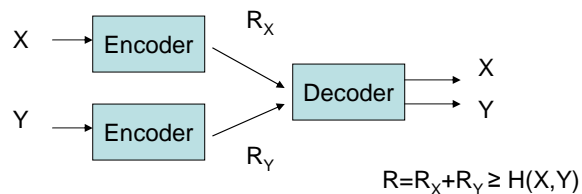

Distributed source coding with decoder side-information:

$$\begin{aligned} R_Y &\geq H(Y) \\ R_X &\geq H(X|Y) \\ R &\geq H(Y) + H(X|Y) = H(X, Y) \end{aligned}$$

Slepian-Wolf Theorem (cont')

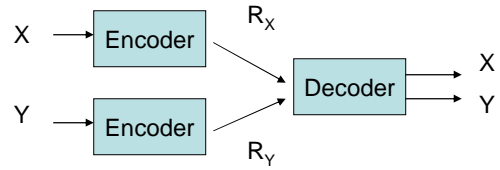

General case:

$$\begin{aligned} R_Y &\geq H(Y|X) \\ R_X &\geq H(X|Y) \\ R &\geq H(X,Y) \end{aligned}$$

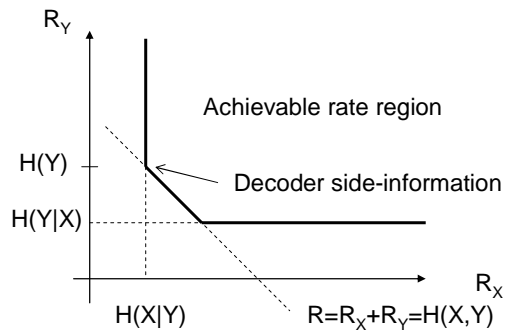

For video/image applications, usually operate at corner points (decoder side-information)

Wyner-Ziv Theorem

- Lossy compression of $\mathbf{X}=\{X\}$, $\mathbf{Y}=\{Y\}$: memoryless sources
- Y is available only at the decoder

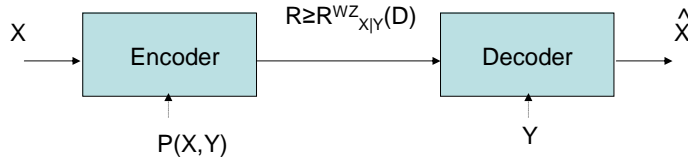
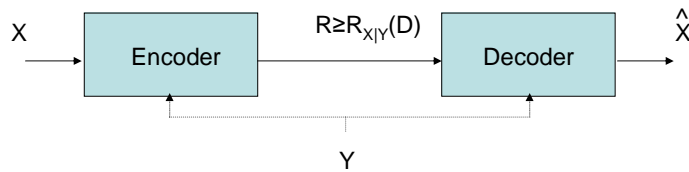

In general, there is rate loss: $R^{WZ}_{X|Y}(D) - R_{X|Y}(D) \geq 0$

Wyner-Ziv Theorem – Example

- Example: quadratic Gaussian case
- $\mathbf{X}=\{X\}$, $\mathbf{Y}=\{Y\}$; X , Y are jointly Gaussian
- Distortion metric is MSE
- No rate loss with Wyner-Ziv coding
- $R^{\text{WZ}}_{X|Y}(D) = R_{X|Y}(D)$

- No rate loss in several other cases

Practical Wyner-Ziv Coding

- Practical Wyner-Ziv coding:

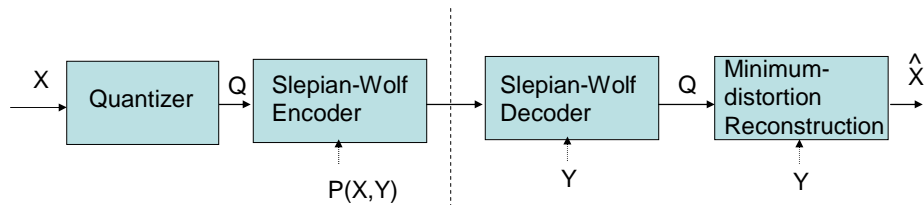

- Lossy quantization
- Lossless compression of quantization index Q using SW encoder
- At decoder, side information Y is used in:
 - Slepian-Wolf decoding
 - Reconstruct X in the quantization bin specified by Q
- To achieve Wyner-Ziv limit, need
 - Good quantization: E.g., TCQ
 - Good Slepian-Wolf code: E.g., based on LDPC

Practical Slepian-Wolf Code Construction

- Slepian-Wolf encoder plays a similar role as entropy coding in conventional source coding problem

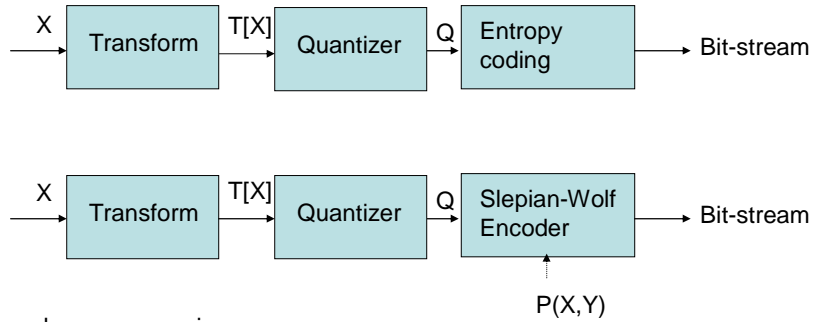

- Lossless compression
- Rely on transform, quantization to achieve good (lossy) coding performance

SW Coding with Error Correcting Code

- Linear (n, k) binary error-correcting code
 - k bits input to channel encoder
 - n bits output at channel encoder
 - $n-k$ bits redundancy

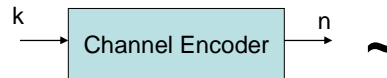

- Defined by parity check matrix H

- For any n -bits binary vector X
 - $X H^T = S$, S is syndrome ($n-k$ bits vector)
 - If X is one of the 2^k codeword, $S=0$
 - In general, 2^k different X have the same S
 - Partition space of X into 2^{n-k} cosets
 - Each coset has 2^k members
 - In each coset, the minimum (Hamming) distance between the members is the same

Space of n -bits binary vector:

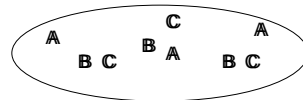

$$X H^T = S \quad \begin{matrix} 2^n \text{ members} \\ 2^k \text{ members} \end{matrix}$$

LDPC Based Slepian-Wolf Code

- $X=\{X\}, Y=\{Y\}$, to compress a n-bits binary vector X
- **Similar idea as the coset example we have mentioned**

Encoder:

- Partition input space into cosets:
- Send coset index:



$X \bmod m = \text{coset index}$

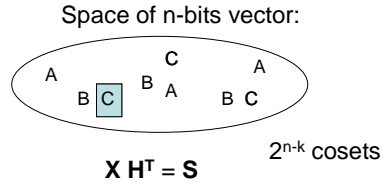

Decoder:

- Use Y to disambiguate the information:

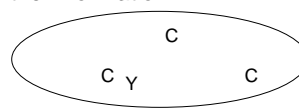
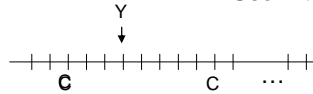

- **Compression performance: $(n-k)/n$**
- **Number of cosets (min. distance between members of coset) depends on correlation**

LDPC Based Slepian-Wolf Code (cont')

SW Encoder:

$X H^T = S$

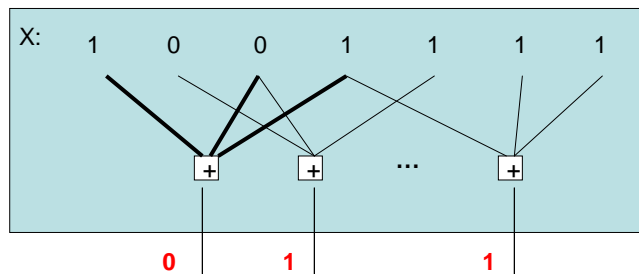

SW Decoder:

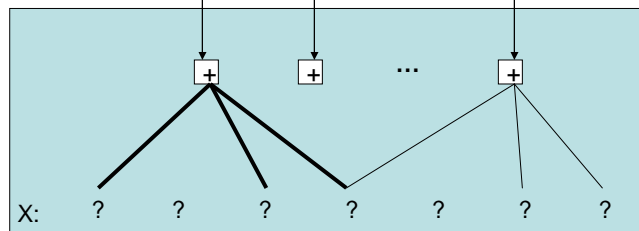

$p(X_i | Y_j)$

Decoder would use the SI to estimate the probability that each bit is being zero or one

Outline

- Introduction
 - Motivation
 - Source coding with decoder side-information only
 - Simple example to illustrate DSC idea
 - Application scenarios
- Basic information-theoretic results
 - Slepian-Wolf
 - Wyner-Ziv
- Practical encoding/decoding algorithm
 - Role
 - LDPC based
- Applications
 - Low-complexity video encoding
 - Scalable video coding
 - Flexible decoding, e.g., multiview video

Low Complexity Video Encoding

- Shift motion estimation to decoder
- Low complexity video encoder
- High complexity decoder
- Application: uplink video transmission
 - Video sensor network
 - Mobile phone video
- Important work:
 - [Puri, Ramchandran; 2002]
 - [Aaron, Zhang, Girod; 2002]

Low Complexity Video Encoding - Example

- [Puri, Ramchandran; 2002], [Puri, Majumdar, Ramchandran; 2007]
- DSC requires only $P(X,Y)$ at encoder
 - X: current macroblock to be encoded
 - Y: best motion-compensated predictor from reference frame for X
- Two problems:
 - At encoder, how to estimate $P(X,Y)$ without searching Y?
 - For low complexity encoding, avoid ME at encoder
 - At decoder, how to obtain Y to decode X?
 - Conventional ME requires X to locate Y
 - X is not available

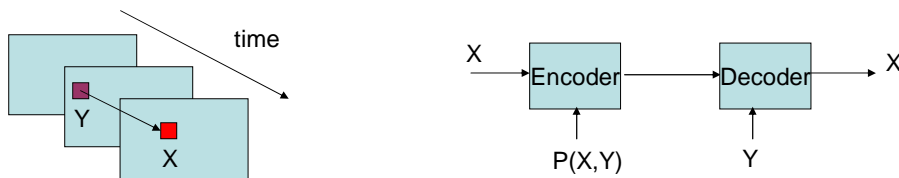

Low Complexity Video Encoding – Example (cont')

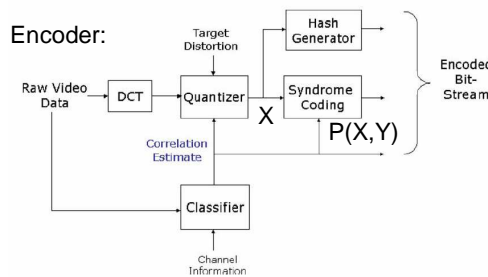

- Block based
- Transform, Quantization, Syndrome coding
- Estimate $P(X,Y)$:
 - Squared difference (SD) between co-located block in previous frame
 - Use SD to infer $P(X,Y)$ thro' classifier
 - Require no motion search

[Puri, Majumdar, Ramchandran; IEEE Trans. IP 2007]

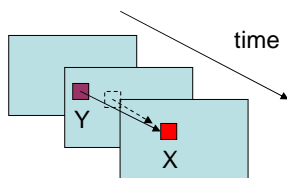

Decoder:

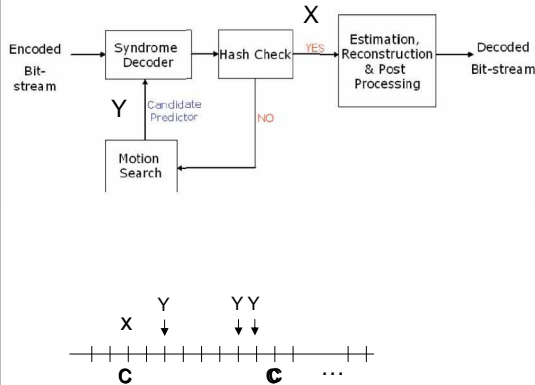

- Require Y (best motion-compensated predictor) to perform Slepian-Wolf decoding
- Conventional ME requires X to locate Y
- But X is not available
 - Encoder sends also CRC of X
 - At decoder, try all possible candidate predictors
 - For each candidate predictor, SW decoder outputs one decoded sequence closest to the candidate
 - If the decoded sequence passes CRC test, declare current decoded sequence as X
 - Otherwise, try another candidate

- Compared to H.263+, FEC, Intra-refresh

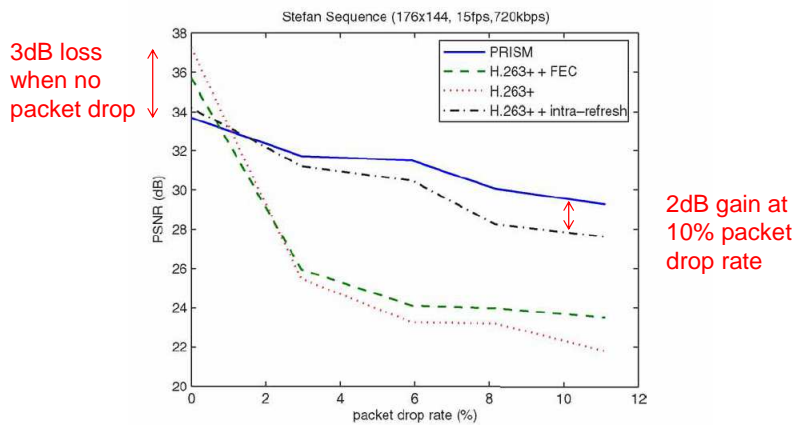

[Puri, Majumdar, Ramchandran; IEEE Trans. IP 2007]

DSC Application to Scalable Video Coding

Some Work on Scalable Coding Based on DSC

- [Xu, Xiong; VCIP 04, IEEE Trans. IP 06]
 - Embedded enhancement layer similar to MPEG-4/H.26L FGS
 - Robust to error in base layer
 - Do not suffer performance loss due to layering
- [Tagliasacchi, Majumdar, Ramchandran, Tubaro; PCS 04, Eurasip SP 06]
 - Spatial/temporal/SNR scalability
 - Based on PRISM [Puri, Ramchandran; Allerton 02]
 - Robust to channel losses
 - Flexible distribution of complexity
- [Sehgal, Jagmohan, Ahuja; PCS 04]
 - Multiple Wyner-Ziv encoded versions for different possible predictors
 - Encoder streams an appropriate encoded version based on knowledge of predictors available at decoder
- [Wang, Cheung, Ortega; PCS 04, Eurasip JASP 06]
 - Improvement of MPEG4-FGS: Utilizing EL reconstruction for prediction
 - Low complexity overhead: Avoid replicating EL reconstruction at encoder

Error Robust Scalable Coding

[Xu, Xiong; VCIP 04, IEEE Trans. IP 06]

Base layer (BL): Standard video codec

Side Information (SI): BL reconstruction

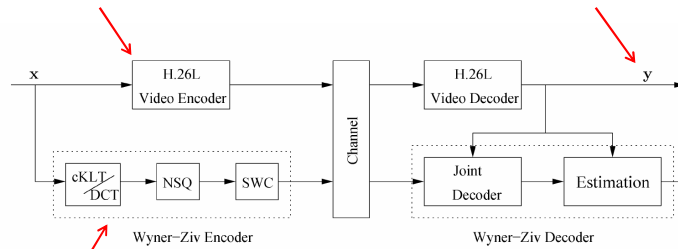

Enhancement layer (EL) based on bit-plane coding and DSC

Error corrupted base layer (SI) may still be used for DSC decoding

Robust to Transmission Error

DSC-based system can achieve substantial improvement in situations with transmission error

[Xu, Xiong; VCIP 04, IEEE Trans. IP 06]

Football
1% macroblock loss at BL
BL: 1450 kbps
EL: 200 kbps

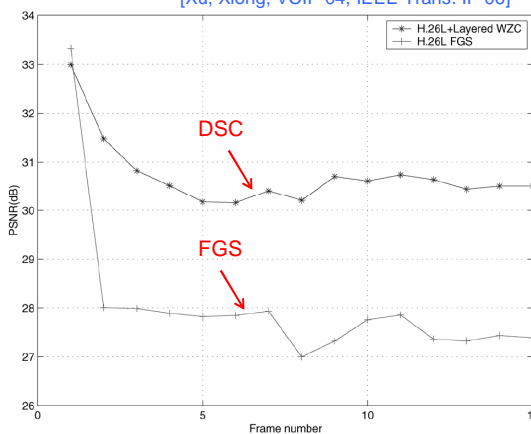

In addition, the system does not suffer performance loss due to layering, i.e., same performance as the monolithic WZ coding

DSC Application to Flexible Video Decoding

Flexible Video Decoding

Apply DSC to generate a *single* bitstream that can be decoded in *several* different ways

- Free viewpoint switching in multiview video compression
- Forward and backward video playback
- Robust video transmission

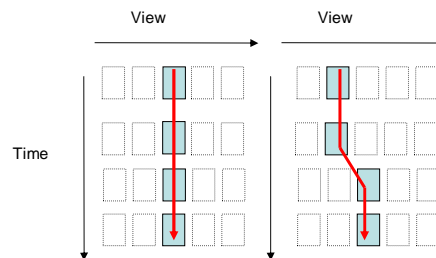

Flexible Decoding Example – Free Viewpoint Switching in Multiview Video

[Cheung, Ortega; PCS 07]

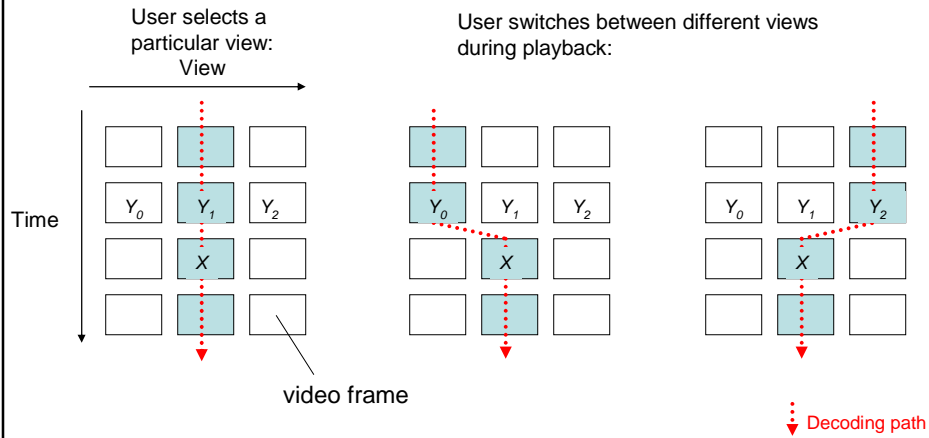

In order to address viewpoint switching, compression schemes have to support **multiple decoding paths**

Free viewpoint switching poses challenges to multiview compression

When users can choose among different decoding paths, it is not clear which previous reconstructed frame will be available to use in the decoding

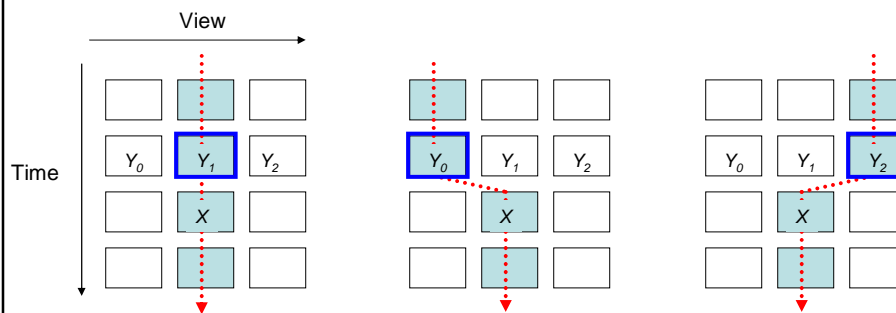

Multiple decoding paths



Either Y_0 or Y_1 or Y_2 will be available at decoder



Uncertainty on predictor status at decoder!!!!

Problem Formulation

To support low-delay free viewpoint switching (flexible decoding),
encoder needs to operate under uncertainty on decoder predictor

[Cheung, Ortega; MMSP 07]

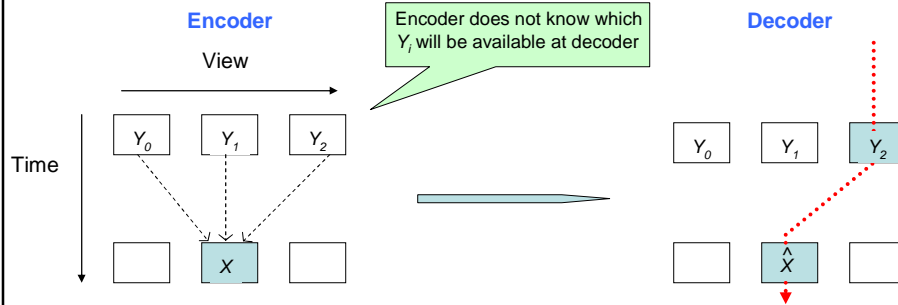

- Assume feedback is not available
 - Low-delay, interactive application
 - Offline encoding of multiview data

Address Viewpoint Switching/Flexible Decoding Within Closed-Loop Predictive (CLP) Coding Framework

Encoder has to send **multiple** prediction residues to the decoder

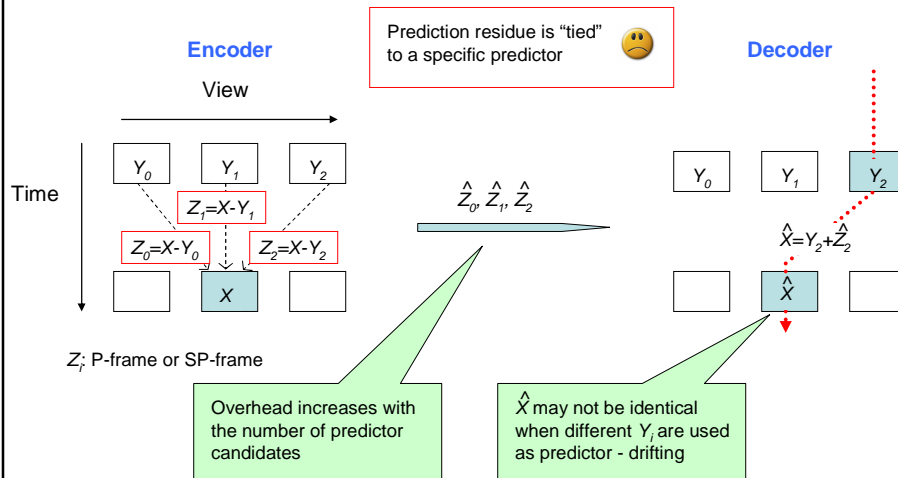

Solution Based on Distributed Source Coding

DSC - Virtual Communication Channel Perspective

In DSC, encoder can communicate X by sending **parity information**
(E.g., [Girod, Aaron, Rane, Rebollo-Montero; Proc. IEEE 04])

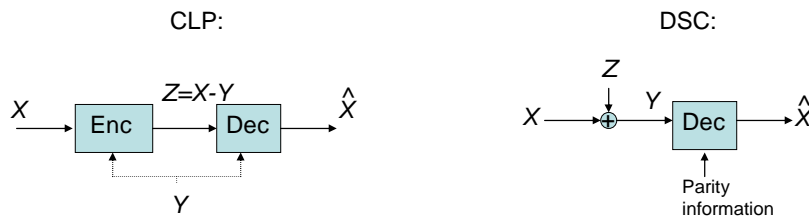

Parity information is **independent** of a specific predictor
- What matters is the **amount** of parity information

Address Viewpoint Switching (Flexible Decoding) Using DSC

Under predictor uncertainty, encoder can communicate X by sending an amount of parity corresponding to the **worst case correlation**

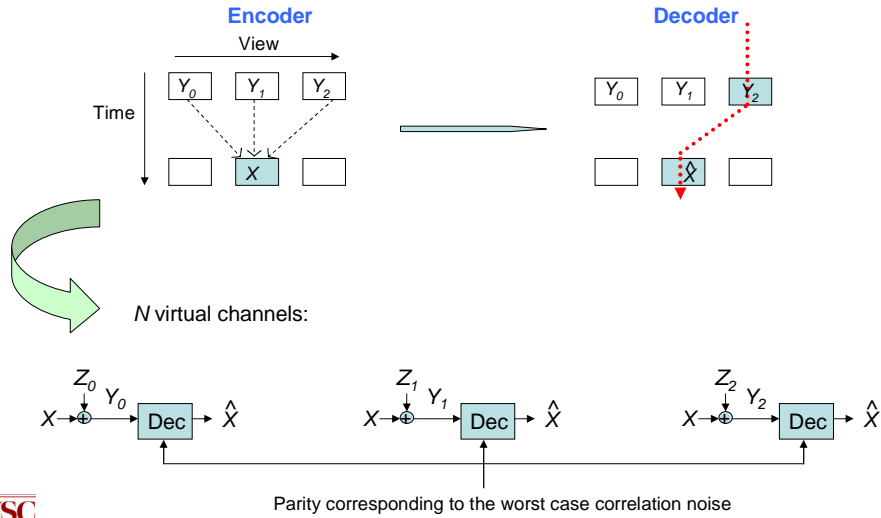

Viewpoint Switching (Flexible Decoding) – CLP vs. DSC

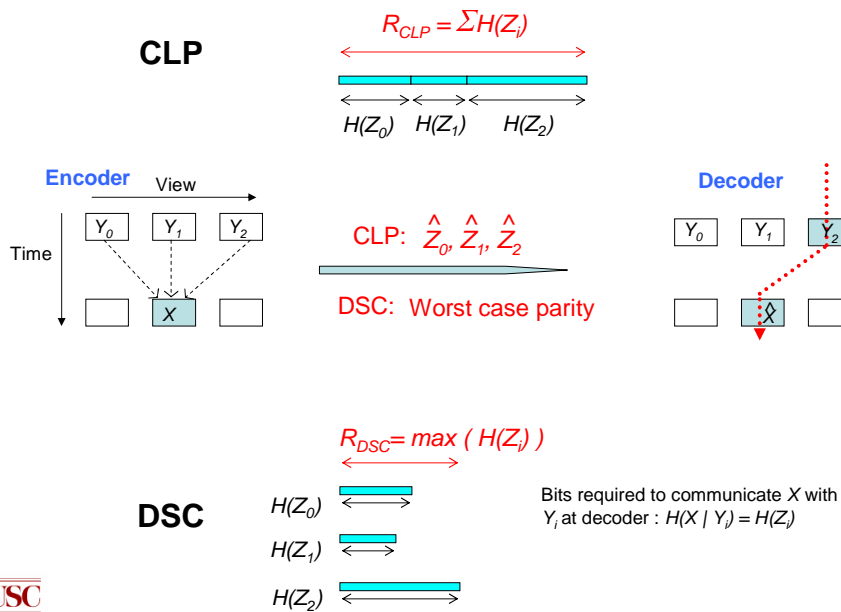

Parity information is independent of a specific predictor

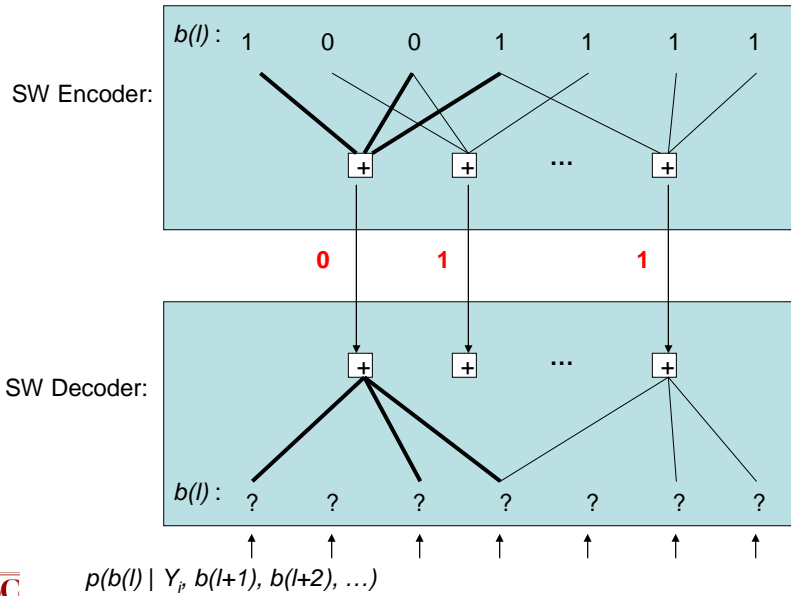

82

Experimental Results - Multiview Video Coding

Allow switching from adjacent views: three predictor candidates

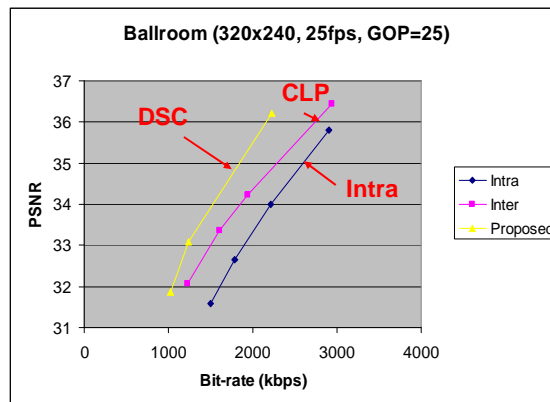
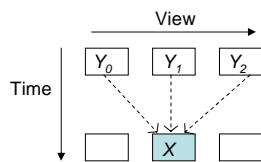

Our proposed algorithm out-performs CLP and intra coding

88

Experimental Results

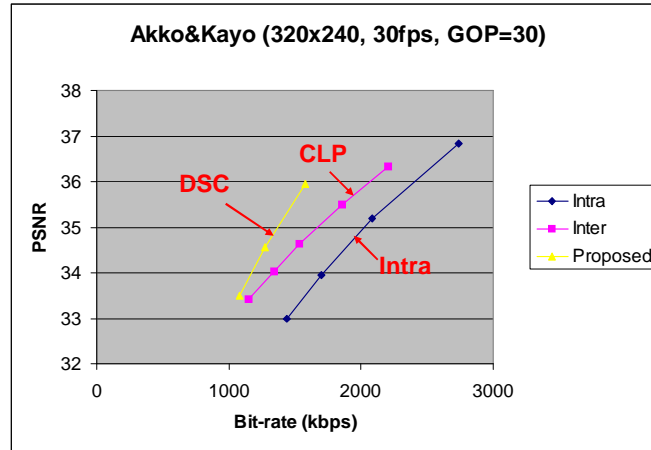

Drifting Experiments

Our proposed algorithm is almost drift-free, since quantized coefficients in DSC coded MB are identically reconstructed

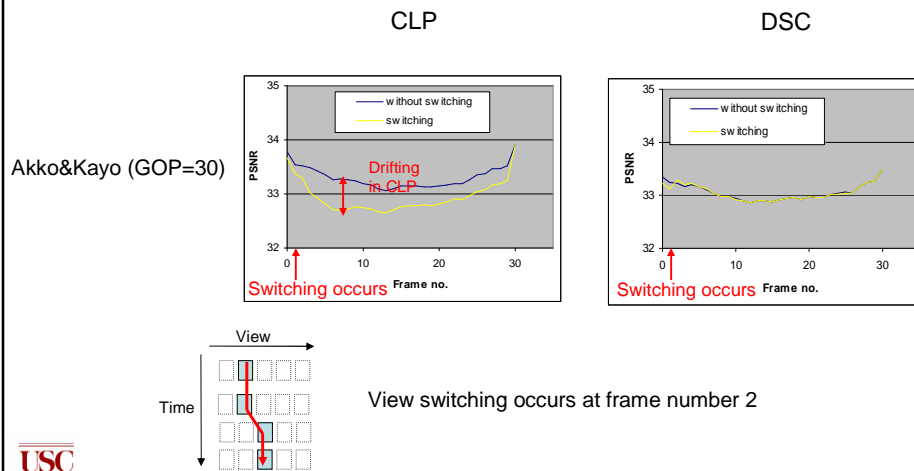

Scaling Experiments

- Number of coded bits vs. number of predictor candidates

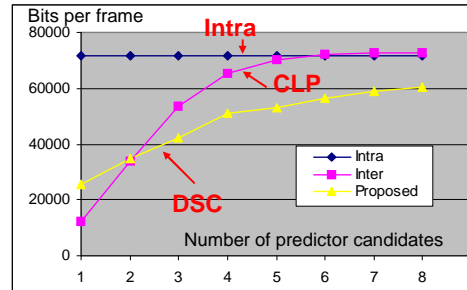
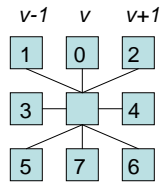

- Bit-rate of DSC-based approach increases at a slower rate compared with CLP
 - An additional candidate incurs more bits only if it has the worst correlation among all candidates

Summary: DSC Application to Viewpoint Switching/Flexible Decoding

- DSC-based coding algorithm to address viewpoint switching/flexible decoding
 - **Single** bitstream to support **multiple** decoding paths
 - Parity information **independent** of a specific predictor
 - Overhead depends on the **worst correlation** rather than the number of decoding paths
 - Outperform CLP and intra coding in terms of coding performance
 - Our proposed system is almost drift-free

- Introduction
 - B. Girod, A. Aaron, S. Rane, and D. Rebollo-Monedero, "Distributed video coding," Proceedings of the IEEE, Special Issue on Advances in Video Coding and Delivery 93, pp. 71-83, Jan. 2005.
 - Z. Xiong, A. Liveris, and S. Cheng, "Distributed source coding for sensor networks," IEEE Signal Processing Magazine 21, pp. 80-94, Sept. 2004.

- Recent Advances
 - Guillemot, C., Pereira, F., Torres, L., Ebrahimi, T., Leonardi, R., Ostermann, J., "Distributed Monoview and Multiview Video Coding," Signal Processing Magazine, IEEE, Volume 24, Issue 5, Sept. 2007, Page(s):67 - 76
 - Workshop on Recent Advances in Distributed Video Coding
<http://www.discoverdvc.org/Workshop.html>